

Instructions for wear checks of play equipment

The equipment must be checked for correct operation and safety, especially the points listed below:

Proof of maintenance

Playground.....

Date of installation

Checks depend on the type of equipment. Any equipment with moving parts must be checked at least twice a year, static equipment at least once a year.

Intervals for maintenance work and checks generally depend on

- location
- usage
- frequency of use
- possible vandalism

For more details see also „General instructions for maintenance of playgrounds“.

Maypole
Order No. 7.16000

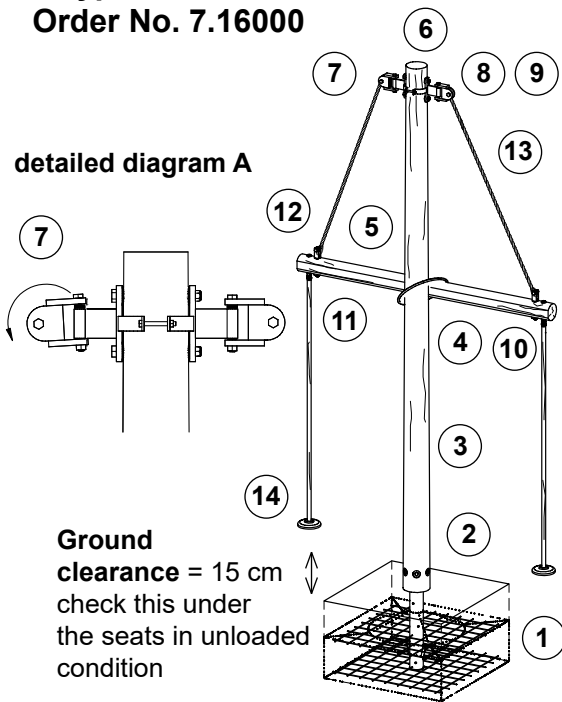

detailed diagram B
measure the abrasion depth

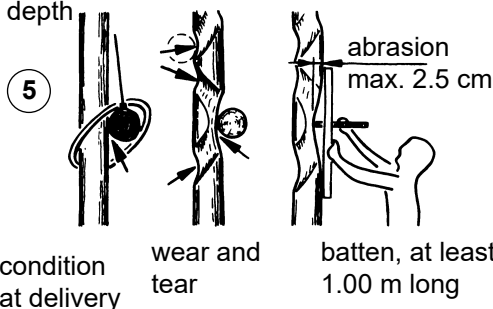

Wooden parts

1. Check for rot and, if necessary, smooth out splinters and round off sharp edges of cracks.
2. Thoroughly grease the contact areas of the two wooden posts (universal grease, order No. 0.94445).
3. Check the abrasion depth (**see detailed diagram B**). Take the equipment out of service if the abrasion depth gets close to 5 cm.
4. **Recommendation:** apply paraffin wax to the upper end grain areas once a year, please refer to order No. 0.90100, 1 litre.

Winding mechanism

5. **Attention!** Hanging “ears” are a sign of strong wear and tear (**see detailed diagram A**).
6. Check that the upper joints move smoothly.
7. Conduct a visual check of the pivot bolts.
8. Check winding ropes for wear and tear and ensure they are securely connected. Replace after three years the latest.

Pendulum seat suspension

9. Check that joint can move smoothly in both directions.
10. Check connection to wood, bearing plate must fit closely.
11. Check chain and connection to chain, the first chain link must be locked.
12. Check pendulum seats and hose sleeves for damage and replace if necessary. For pendulum seats with exposed metal parts, it is imperative they be replaced.

Structural stability

13. **Attention!** One-legged equipment: In order to check the posts for rot, uncover the foundations twice a year.

Repair not carried out, it is still possible to play on equipment

Repair not carried out, equipment is taken out of action

All work carried out, everything is in order

Maintenance carried out by:

..... Date

Special notes, e.g. for repairs

For spare parts refer to page 3

Additional notes

Maintenance of one post equipment

This product is a one post equipment according to EN 1176-1.
Equipment of this kind requires special diligence with regard to planning, construction and maintenance.

In this document, you will find additional maintenance notes.

The following principles generally apply to one post equipment:

The longer the equipment has been in operation, the more diligence is required during maintenance.
Dynamic loads additionally stress the structural stability.
Frequency of use and a given excessive load must be taken into account when scheduling maintenance.

The goal of any inspection must be to ensure that the equipment can be safely used until the next check is due.

It is important to pay attention to the following special aspects for safe operation of one post equipment during regular inspections:

- Check the structural stability **twice a year**, uncover the foundations to do this
- Examine the earth/air zone of stand posts with extra care
- Measures for ensuring structural stability of load-bearing wooden components
 - knocking test: the clearer the sound the “healthier” the wood
 - hammer and nail test: the clearer the sound becomes as the nail is hammered in deeper and deeper, the “healthier” the wood
 - incremental drill test (spot-related information): provides very reliable information on the “internal” condition of the cross-section of the wood in one spot by enabling the person conducting the test to visually check the specimen, rub it between their fingers and smell on it
 - resistograph (spot-related information): very good information on the internal solidity of the wood, however, only experienced experts are able to interpret the measurement graphs
 - ensile test: load test resulting in highly relevant safety-related information (see separate instructions)

Permadur system as an additional measure for strengthening the structural stability

Wooden stand posts protected by the Permadur system (i.e. the part buried in the ground is protected by a black heat-shrink tube and metal foil) are checked in almost the same manner.

A 500 g hammer with a polyamide head (soft-faced hammer) is used to tap the post. Thus, the heat-shrink tube will not be damaged.

If the post is checked by determining the drill resistance (e. g. resistograph), drilling through the heat-shrink tube and metal foil is possible. However, the drill hole must be sealed with a dowel afterwards.

Spare Parts
Maypole
Order No. 7.16000

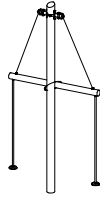

Please note that the safety standards of the equipment must not be affected. Therefore, when carrying out repairs it is helpful to **only use original parts**.

Order No. Spare part

Order No. Spare part

0.94400 pendulum seat with suspension

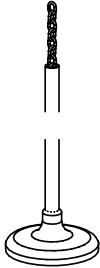

0.94440 guide ring

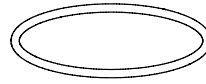

0.94140 hose sleeve for chain

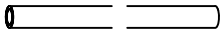

0.94445 universal grease
 (without illustration)

0.92403 Chain without fasteing
 (without illustration)

0.94110 pendulum seat without disc

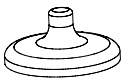

0.94120 disc for pendulum seat



0.92330 joint for pendulum seat



0.94410 winding mechanism

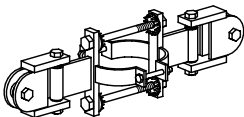

0.94420 winding rope



0.94430 forked bolt M 20

